



HGM6120U2C

HGM6100U2C series automatic controller, integrating digital, intelligent and network techniques, is used for automatic control and monitoring system of genset. It can carry out functions of automatic start/stop, data measurement, alarm protection and three “remote” (remote control, remote measure and remote communication). The controller uses LCD display, optional display interface including Chinese, English, Spanish, Russian, Portuguese, Turkish, Polish and French with easy and reliable operation.

Product Code : 6010068

Power Supply : DC(8-35)V

Case Dimensions : 197*152*47(mm)

Panel Cutout : 186*141(mm)
Operating Temp. : (-25~+70)°C
Weight : 0.56kg

COMPLETE DESCRIPTION

HGM6100U2C series automatic controller, integrating digital, intelligent and network techniques, is used for automatic control and monitoring system of genset. It can carry out functions of automatic start/stop, data measurement, alarm protection and three “remote” (remote control, remote measure and remote communication). The controller uses LCD display, optional display interface including Chinese, English, Spanish, Russian, Portuguese, Turkish, Polish and French with easy and reliable operation.

HGM6100U2C series automatic controller uses micro-processing technique which can achieve precision measurement, value adjustment, timing and threshold setting etc.. All the parameters can be configured from front panel or use RS485 interface to adjust via PC. It can be widely used in all types of automatic control system for its compact structure, simple connections and high reliability.

Performance and characteristics

HGM6100U2C controller has two types:

HGM6110U2C: Used for single unit automation. It controls generator to start/stop by remote start signal;

HGM6120U2C: Based on **HGM6110U2C**, it adds mains AC monitoring and mains/generator automatic switching control (AMF), especially suitable for the automation system composed by mains and genset.

1. 132*64 LCD display with backlight, optional language interface (Simplified Chinese, English, Spanish, Russian, Portuguese, Turkish, Polish and French), push-button operation;
2. Acrylic screen, improved wearability and scratch resistance property;
3. Silica-gel panel and keys can well adapt to higher and lower temperature;
4. With double RS485 communication ports, can achieve “three remote” functions via MODBUS protocol;
5. Adapt to 3P4W, 3P3W, 1P2W and 2P3W (120V/240V), 50Hz/60Hz AC power system;
6. Can measure and display 3 phase voltage, 3 phase current, frequency, power parameter of mains/gens;
7. Mains have functions of over/under voltage and lack of phase; Gens have functions of over/under voltage, over/under frequency and over current;
8. Precision measure and display of parameters about engine,
9. Control protection: Automatic start/stop of genset, load transfer(ATS control) and perfect failure display and protection;
10. With ETS, idle speed control, pre-heat control, speed droop/raising control, all of them are relay output;

11. Parameter setting: Allow user to modify setting and store them in internal FLASH memory. The parameters cannot be lost even when power off. All of parameters can be set not only from the front panel, but also use PS485 interface to adjust them via PC.;
12. Multi sensors of temperature, pressure and fuel level can be used directly, parameters can be defined by user;
13. Multi conditions of crank disconnect (speed sensor, oil pressure, generator) can be selected;
14. Power supply range: (8~35)VDC, accommodating to different starting battery volts;
15. All parameters use digital modulation, instead of analog modulation using conventional potentiometer, having improved reliability and stability;
16. Add rubber gasket between shell and controller screen, the waterproof can reach IP55;
17. Controller is fixed by metal fixing clips;
18. Modular design, flame-retardant ABS shell, embedded mounting, compact structure and easy installation.

PARAMETER LIST

Function Item	Parameter
Display	LCD(132*64)
Operation Panel	Silicon Rubber
Language	Chinese & English & Others
Digital Input	5
Relay Output	6
Analogue Input	3
AMF	●
AC System	1P2W/2P3W/3P3W/3P4W
Alternator Voltage	(15~360)V(ph-N)
Alternator Frequency	50/60Hz
kW/Amp Detecting & Display	●
Monitor Interface	LINK/Two RS485
Programmable Interface	LINK/Two RS485
Maintenance	●

Function Item	Parameter
DC Supply	DC(8~35)V
Case Dimensions(mm)	197*152*47
Panel Cutout(mm)	186*141
Operating Temp.	(-25~+70)°C

HGM6120u2c Typical Application

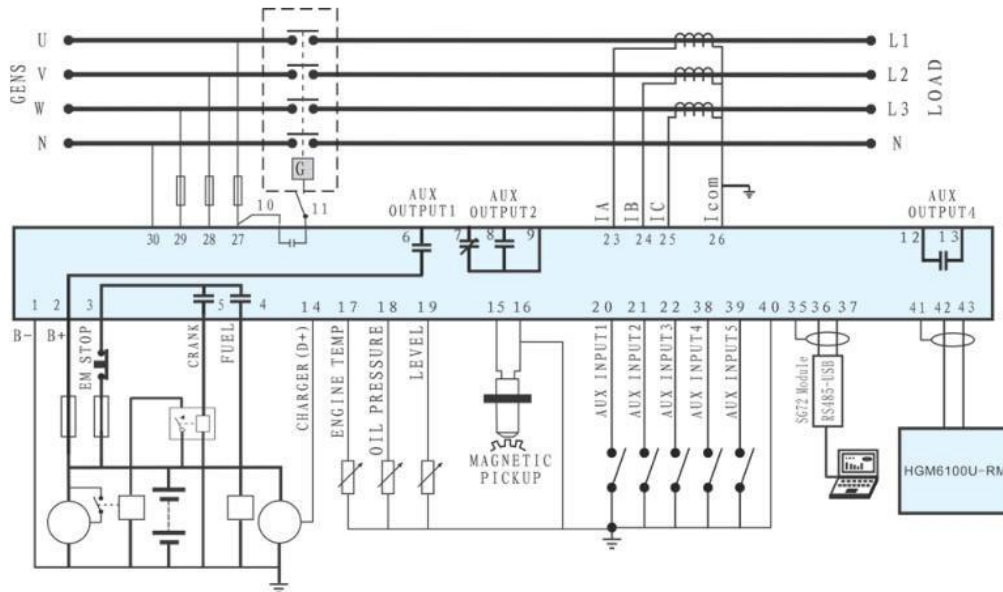

HGM6110U2C Typical Application Diagram

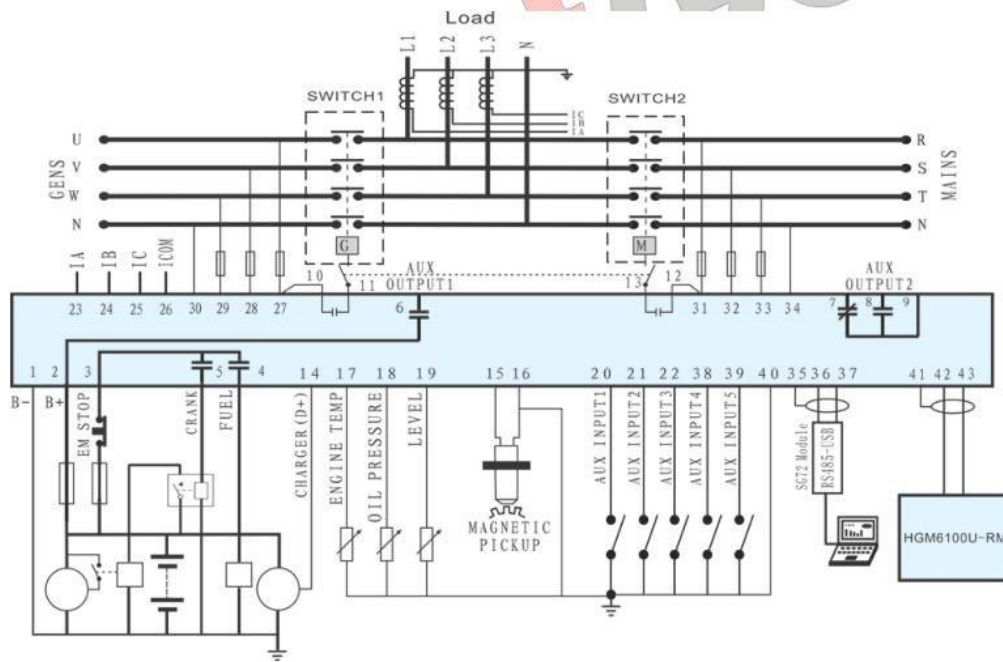

HGM6120U2C Typical Application Diagram